

APPROVAL SHEET

MULTI LAYER CERAMIC INDUCTOR

High Frequency Application Purpose

Size 0201 (0603)

WL0603 Pb-Free Series

*Contents in this sheet are subject to change without prior notice.

FEATURES

1. Ceramic structure provides high reliability · high productivity
2. Product Design via 3D EM Simulation Skill makes excellent Q and SRF characteristics
3. Miniaturized size 0.6 x 0.3 x 0.3 mm³
4. Pb Free products

APPLICATIONS

Portable electronics and wireless segment includes mobile phones, Wireless LAN, HomeRF, Bluetooth application, telecommunication and EMI countermeasure in high frequency circuits.

DESCRIPTION

Walsin Technology Corporation develops a tiny size of 0.6 x 0.3 x 0.3 mm³ Multi Layer Ceramic Inductor (MLCI) consist of a rectangular block of ceramic foils on which low resistive silver metal electrodes are contained and connected via through hole. The inner electrodes are then connected to the two terminations. Adopt 3D EM simulation skill for product design makes Walsin Technology Corporation MLCIs provide excellent Q_Value and Self Resonant Frequency (SRF) characteristics to address application on high frequency band as well as on EMI suppression. The Walsin High frequency chip inductors are manufactured by Multilayer fabrication technology providing excellent electrical performance. The inductors are supplied in reel taping, making them suitable for automatic Pick & Place equipment.

Cooperating with environmental protection, We provided Pb-Free products for customer request.

SHAPE and DIMENSION

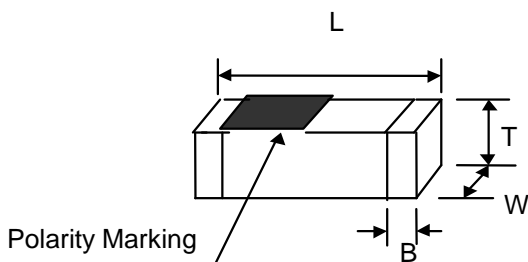

MARKING

Polarity mark



Unit: mm (inches)

	L	W	T	B
0603	0.6 [0.024] ±0.3 [0.001]	0.3 [0.012] ±0.03 [0.001]	0.3 [0.012] ±0.03 [0.001]	0.15 [0.006] ±0.05 [0.002]

Ordering Information

WL	06 03 03	G	1N2	S	G	T	03
Product Code	Dimension code	Material	Inductance	Tolerance	Specification	Packing Code	Rated Current
WL: Inductor	060303 = L: 0.6mm W: 0.3mm T: 0.3mm	A, B, C, D, E, F, G	For Ls < 10nH, N = Decimal Point e.g. 1N2 = 1.2nH	B: ± 0.1nH S: ± 0.3nH J: ± 5% K: ±10% C: Customized	N= Normal A= ± 0.2nH G= Green	T= Reeled B = Bulk	03= 250mA or 300mA 02= 150mA or 200mA

ELECTRICAL CHARACTERISTICS

Quality Factor vs. Frequency

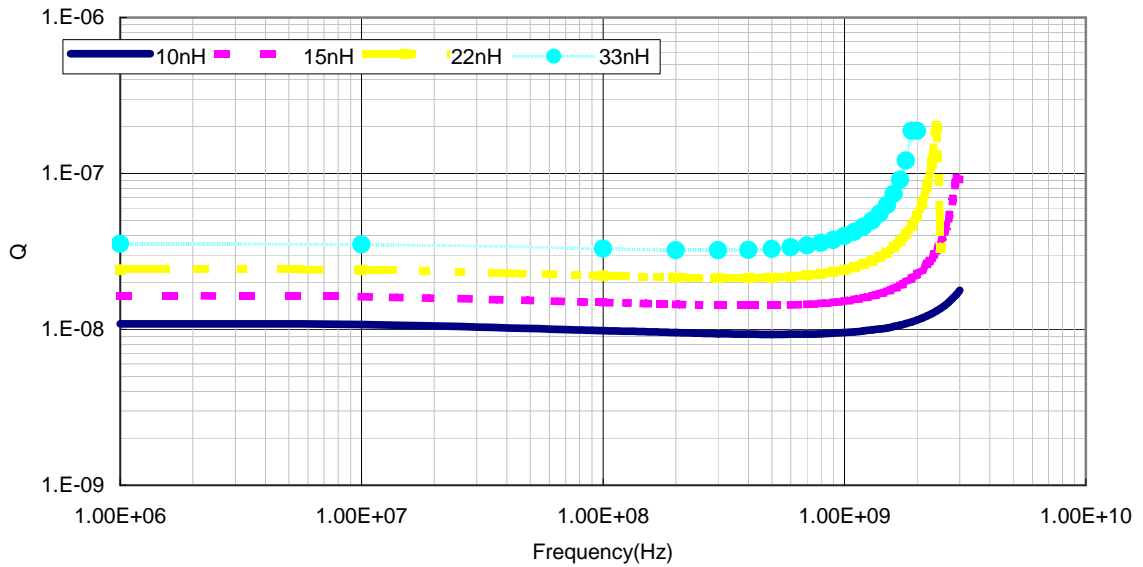

Inductance vs. Frequency

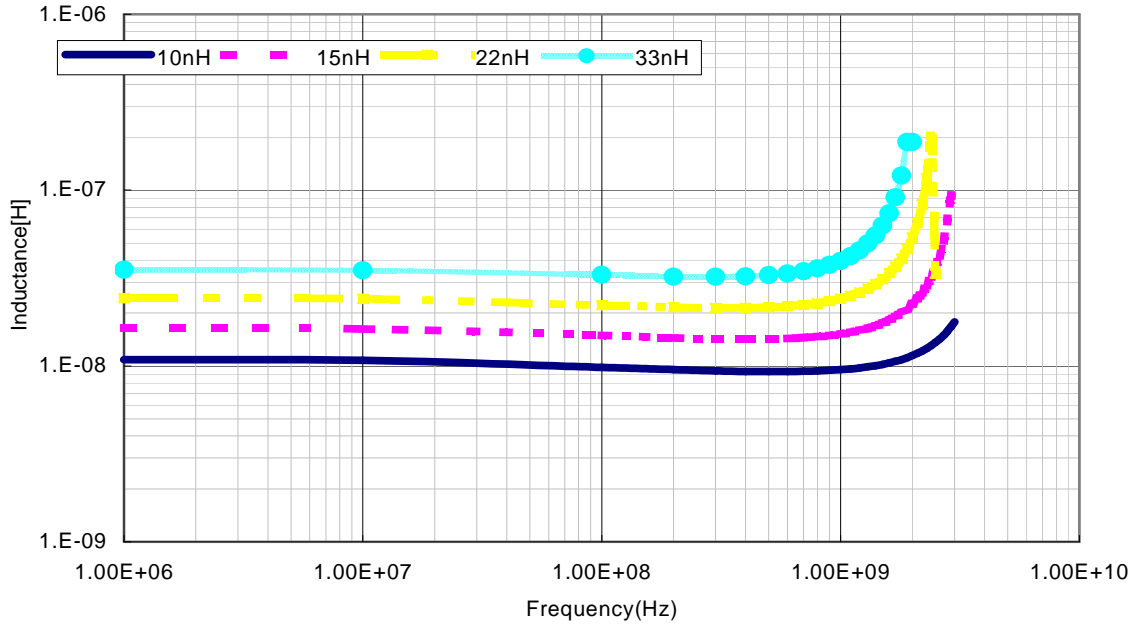

STANARD TEST and RELIABILITY TEST

- Temperature : 15~35°C
- Humidity : 25%RH~85%RH
- Atmospheric pressure : 96kPa ~ 106kPa

1. Electrical performance test

Item	Method & Criteria
Inductance/Q(Quality factor)	Unit : nH/Constant Test frequency : 100MHz Equipment : Impedance material analyzer
SRF(Self Resonant Frequency)	Unit : MHz Test frequency : Frequency sweep(40MHz~20GHz) Equipment : Network analyzer
DC(Direct Current)resistance	Unit : mΩ(ohm) Test frequency : LCR meter
Rated current	Unit : mA Test frequency : Current Sweep Equipment : Power supply (DC current source)

2. Reliability Test

TCL	Unit : Temperature coefficient of L(PPM/°C) Test Temperature : -40°C~125°C (referring to L at 20°C) Equipment : TC Chamber(with Impedance analyzer, Ohmmeter, power supply PC, Printer) ◇ Basically, DC bias make no difference on L and Q, in glass ceramic inductors Requirements : L shall be within ±10% of the initial value.																				
Thermal Resistance (Temperature cycle)	Unit : Appearance, Electrical Characteristics Test condition : <table border="1" style="margin-left: 20px;"> <thead> <tr> <th>Step</th> <th>1</th> <th>2</th> <th>3</th> <th>4</th> </tr> </thead> <tbody> <tr> <td>Temp.</td> <td>-40±2°C</td> <td>room temp.</td> <td>+125±2°C</td> <td>room temp.</td> </tr> <tr> <td>Time</td> <td>30min</td> <td>2-3min</td> <td>30min</td> <td>2-3min</td> </tr> <tr> <td>Cycle</td> <td colspan="4" style="text-align: center;">100 cycles/test</td> </tr> </tbody> </table> Equipment : TC chamber or Temp. controlled chamber (programmable) Procedure : 1) Measure the initial values(L,Q,Rdc) 2) Carry out the test as described above 3) make measurements after ambient air exposure for 24±2 hours. Requirements : No apparent damage L shall be within ±10% of the initial value. Q shall be within ±20% of the initial value.	Step	1	2	3	4	Temp.	-40±2°C	room temp.	+125±2°C	room temp.	Time	30min	2-3min	30min	2-3min	Cycle	100 cycles/test			
Step	1	2	3	4																	
Temp.	-40±2°C	room temp.	+125±2°C	room temp.																	
Time	30min	2-3min	30min	2-3min																	
Cycle	100 cycles/test																				

Humidity Resistance	<p>Unit : Mechanical, Electrical Characteristics</p> <p>Test condition : Humidity :90-95%RH Temp :60°C Time : 500±12 hours neglected.</p> <p>Equipment : Constant temperature & humidity chamber</p> <p>Procedure : 1) Measure the initial values(L,Q,Rdc) 2) Carry out the test as described above 3) make measurements after ambient air exposure for 24±2 hours.</p> <p>Requirements : No apparent damage L shall be within ±10% of the initial value. Q shall be within ±20% of the initial value.</p>
High Temperature Resistance	<p>Unit : Mechanical, Electrical Characteristics</p> <p>Test condition : Temp.; 125±2°C Time ;1000±12 hours under unloading.</p> <p>Equipment : Constant temperature & humidity chamber</p> <p>Procedure : 1) Measure the initial values(L, Q, Rdc) 2) Carry out the test as described above 3) make measurements after ambient air exposure for 24±2 hours.</p> <p>Requirements : No apparent damage L shall be within ±10% of the initial value. Q shall be within ±20% of the initial value.</p>
Low Temperature Resistance	<p>Unit : Mechanical, Electrical Characteristics</p> <p>Test condition : Temp.; -40±2°C Time ;1000±12 hours under unloading.</p> <p>Equipment : Constant temperature & humidity chamber</p> <p>Procedure : 1) Measure the initial values(L, Q, Rdc) 2) Carry out the test as described above 3) make measurements after ambient air exposure for 24±2 hours.</p> <p>Requirements : No apparent damage L shall be within ±10% of the initial value. Q shall be within ±20% of the initial value.</p>

8585 Test	<p>Unit : Mechanical, Electrical Characteristics</p> <p>Test condition : Temp. : 85±2°C Humidity : 85±5% Time : 100±12 hours</p> <p>Equipment : Constant temperature & humidity chamber</p> <p>Procedure : 1) Measure the initial values(L, Q, Rdc) 2) Carry out the test as described above 3) Make measurements after the ambient air exposure for 24±2 hours</p> <p>Requirements : No mechanical damage L shall be within ±10% of the initial value. Q shall be within ±20% of the initial value.</p>
Loading under Damp Heat	<p>Unit : Mechanical, Electrical Characteristics</p> <p>Test condition : Temp : 60±2°C Humidity : 90~95%RH Time : 500±12 hours Apply current: Rated current</p> <p>Equipment : Constant temperature & humidity chamber</p> <p>Procedure : 1) Measure the initial values(L, Q, Rdc) 2) Carry out the test as described above 3) Make measurements after the ambient air exposure for 1 to 2 hours of recovery</p> <p>Requirements : No mechanical damage L shall be within ±10% of the initial value. Q shall be within ±20% of the initial value.</p>
Loading at High Temperature	<p>Unit : Mechanical, Electrical Characteristics</p> <p>Test condition : Temp : 125±2°C Time : 500±12 hours Apply current: Rated current</p> <p>Equipment : Constant temperature & humidity chamber</p> <p>Procedure : 1) Measure the initial values(L, Q, Rdc) 2) Carry out the test as described above 3) Make measurements after the ambient air exposure for 1 to 2 hours of recovery</p> <p>Requirements : No mechanical damage L shall be within ±10% of the initial value. Q shall be within ±20% of the initial value.</p>

3. Solderability

Condition	Immerse a test sample into a methanol solution containing rosin and immerse into molten solder of $245\pm 5^{\circ}\text{C}$ for 5~10 seconds.
Requirement	More than 75% of the terminal electrode part shall be covered with fresh solder.

4. Resistance to soldering heat

Condition	-Immerse a test sample into a methanol solution containing resin, preheat it at 120 to 150°C for 1 minutes and immerse into molten solder of $270\pm 5^{\circ}\text{C}$ for 10 ± 1 second so that both terminal electrodes are completely submerged.
Requirement	No visible damage Inductance variation within 10% Q variation within 20%

5. Bending Strength

Condition	Solder the chip to test jig then apply a force in the direction shown in below. The soldering shall be done with the reflow method and shall be conducted with care so that the soldering is uniform and free of defects such as heat shock.
Requirement	1. No mechanical damage shall be observed. 2. Rdc-value: to meet the initial Spec.

6. IR Reflow Profile

The rate of preheat should not exceed $4^{\circ}\text{C}/\text{sec}$ and a target of $2^{\circ}\text{C}/\text{sec}$ is preferred. Ceramic chip components should be preheated to within 100 to 130°C of the soldering

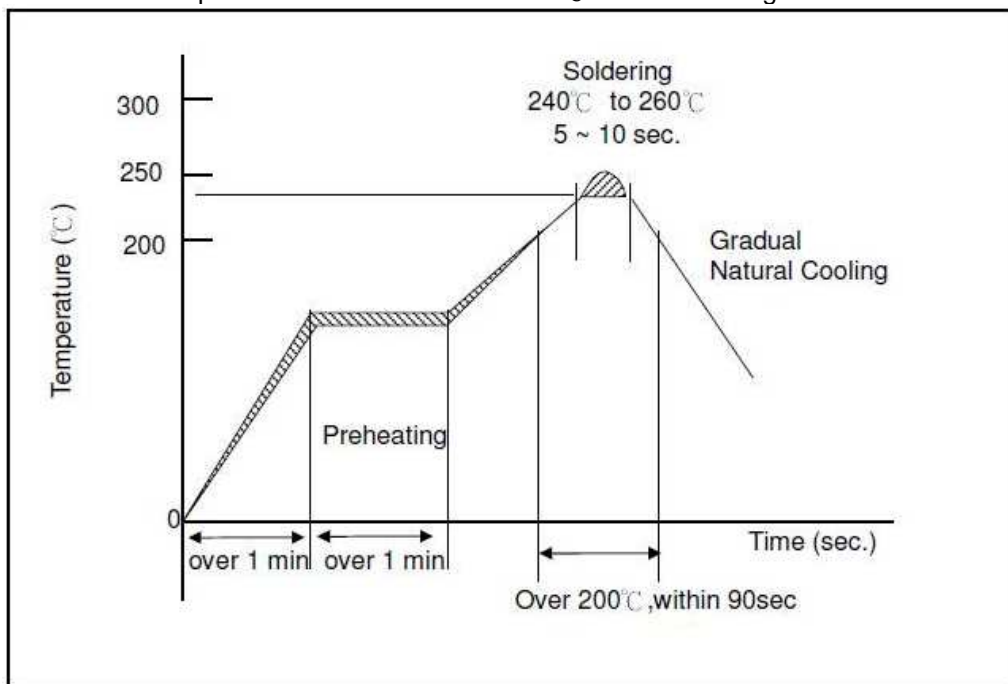

PACKAGE SPECIFICATION

■ Carrier Tape Dimensions

- Carrier Tape material : Paper
- Dimension in millimeters

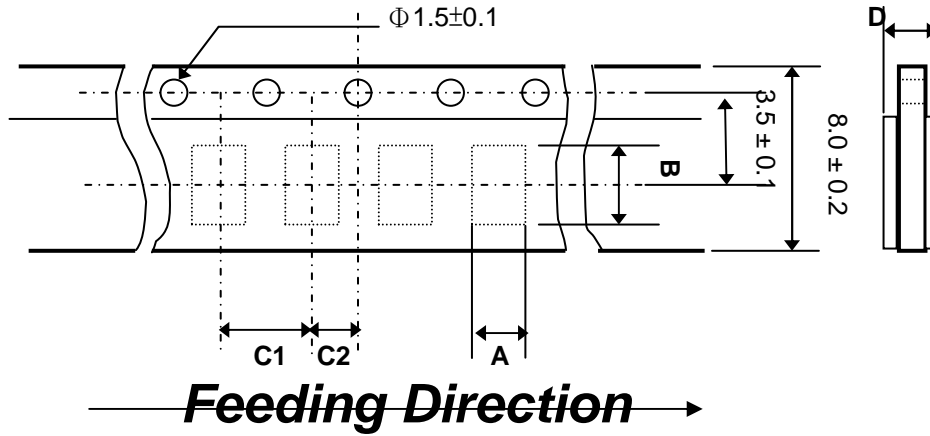

Series	Chip cavity	Chip cavity	Insertion pitch	Insertion pitch	Tape thickness
	A	B	C1	C2	D
0603	0.38 ± 0.02	0.68 ± 0.02	2.0 ± 0.05	2.00 ± 0.05	0.44 Max

Dimensions of Taping

-Leader and blank section

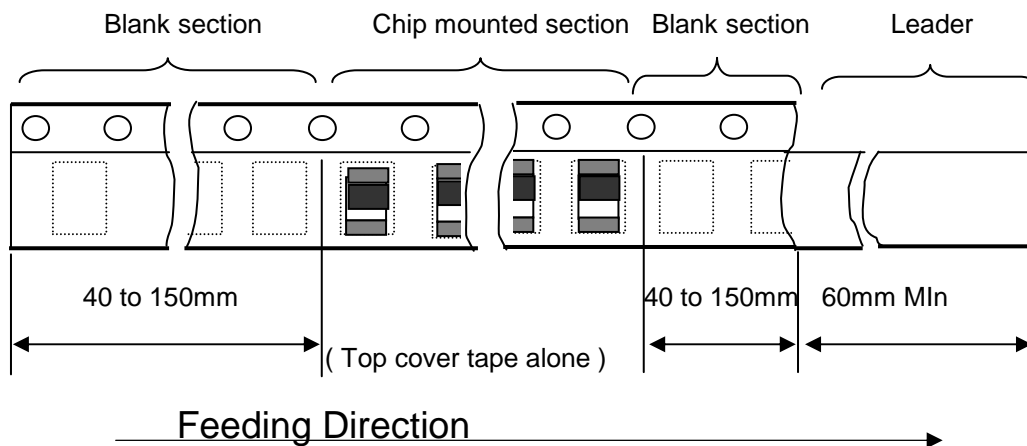

Appearance of taping

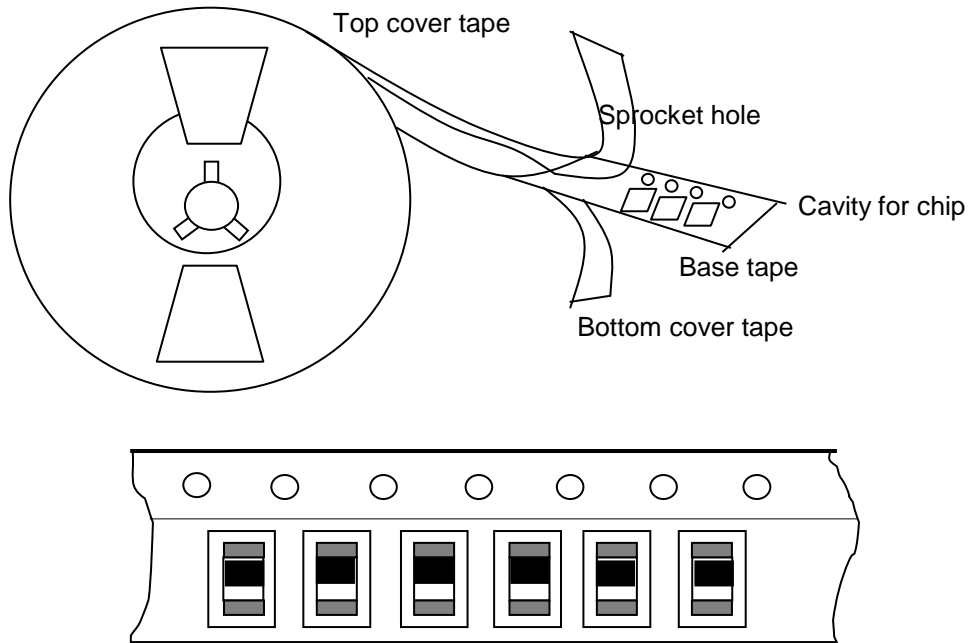

Packed chip

Reel Dimensions

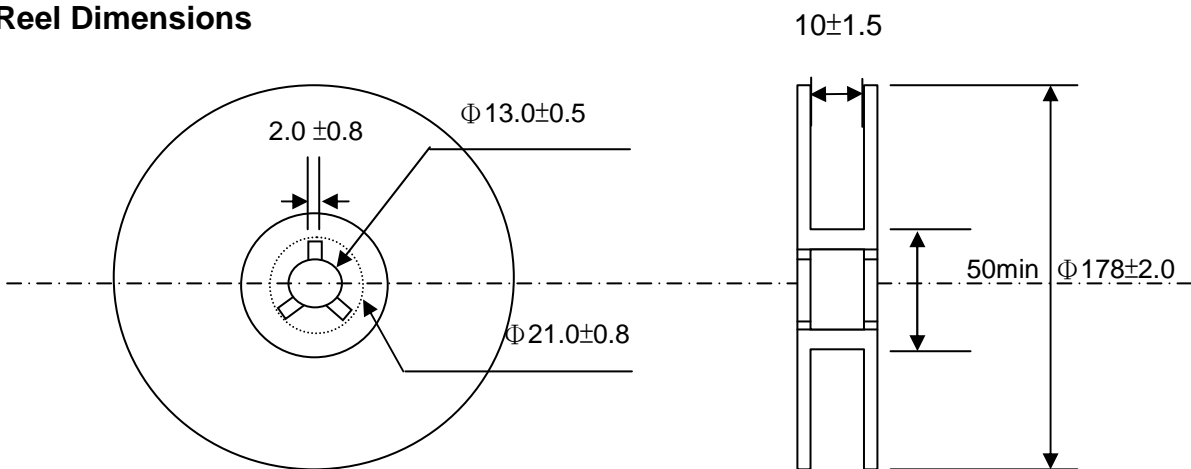

- Reel material : Polystyrene
- Ordering code No., Quantity, Batch No. and Walsin
- Parts per reel : 15,000 pcs / reel

CAUTION OF HANDLING

Limitation of Applications

Please contact us before using our products for the applications listed below which require especially high reliability for the prevention of defects, which might directly cause damage to the third party's life, body or property.

- (1) Aircraft equipment
- (2) Aerospace equipment
- (3) Undersea equipment
- (4) Medical equipment
- (5) Disaster prevention / crime prevention equipment
- (6) Traffic signal equipment
- (7) Transportation equipment (vehicles, trains, ships, etc.)
- (8) Applications of similar complexity and /or reliability requirements to the applications listed in the above.

Storage condition

- (1) Products should be used in 6 months from the day of WALSIN outgoing inspection, which can be confirmed.
- (2) Storage environment condition.
 - Products should be storage in the warehouse on the following conditions.
 - Temperature : -10 to +40°C
 - Humidity : 30 to 70% relative humidity
 - Don't keep products in corrosive gases such as sulfur. Chlorine gas or acid or it may cause oxidization of electrode, resulting in poor solderability.
 - Products should be storage on the palette for the prevention of the influence from humidity, dust and son on.
 - Products should be storage in the warehouse without heat shock, vibration, direct sunlight and so on.
 - Products should be storage under the airtight packaged condition.

APPROVAL SHEET

MULTI LAYER CERAMIC INDUCTOR

High Frequency Application Purpose

Halogens Free Product

Size 0402 (1005)

WL1005 Pb-Free Series

*Contents in this sheet are subject to change without prior notice.

FEATURES

1. Ceramic structure provides high reliability · high productivity
2. Product Design via 3D EM Simulation Skill makes excellent Q and SRF characteristics
3. Miniaturized size 1.0 x 0.5 x 0.5 mm³
4. Pb Free products

APPLICATIONS

Portable electronics and wireless segment includes mobile phones, Wireless LAN, HomeRF, Bluetooth application, telecommunication and EMI countermeasure in high frequency circuits.

DESCRIPTION

Walsin Technology Corporation develops a tiny size of 1.0 x 0.5 x 0.5 mm³ Multi Layer Ceramic Inductor (MLCI) consist of a rectangular block of ceramic foils on which low resistive silver metal electrodes are contained and connected via through hole. The inner electrodes are then connected to the two terminations. Adopt 3D EM simulation skill for product design makes Walsin Technology Corporation MLCIs provide excellent Q_Value and Self Resonant Frequency (SRF) characteristics to address application on high frequency band as well as on EMI suppression. The Walsin High frequency chip inductors are manufactured by Multilayer fabrication technology providing excellent electrical performance. The inductors are supplied in reel taping, making them suitable for automatic Pick & Place equipment.

Cooperating with environmental protection, We provided Pb-Free products for customer request.

SHAPE and DIMENSION

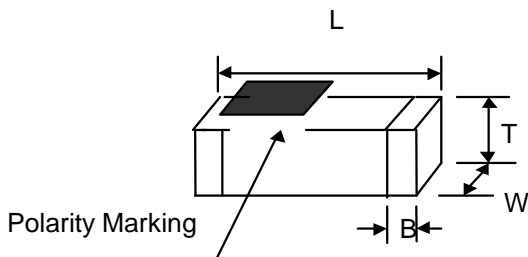

MARKING

Polarity mark



Unit: mm (inches)

	L	W	T	B
1005	1.0[0.040] ±0.1 [0.004]	0.5 [0.020] ±0.1 [0.004]	0.5 [0.020] ±0.1 [0.004]	0.25 [0.010] ±0.10 [0.004]

Ordering Information

WL	10 05 05	G	4N7	S	G	T	03
Product Code	Dimension code	Material	Inductance	Tolerance	Specification	Packing Code	Rated Current
WL: Inductor	100505 = L: 1.0mm W: 0.5mm T: 0.5mm	A, B, C, D, E, F, G	For Ls < 10nH, N = Decimal Point e.g. 4N7 = 4.7nH	B: ± 0.1nH S: ± 0.3nH J: ± 5% K: ±10% C: Customized	N= Normal A= ± 0.2nH G= Green	T= Reeled B = Bulk	03= 250mA or 300mA 02= 150mA or 200mA

Electrical Characteristics – 0402 MLCI

■ Operating Temperature range : -40°C ~ 100°C

Walsin Part Number	L(nH)	Tolerance	Q Min (MHz)	Typical Q @ Frequency (MHz)			SRF Typical (MHz)	RDC Maximum (Ω)	IDC (mA)
			100	100	800	1800			
WL100505G1N0SGT03	1.0	± 0.3nH	8	9	27	44	13000	0.12	300
WL100505G1N2SGT03	1.2	± 0.3nH	8	9	25	45	12000	0.12	300
WL100505G1N3SGT03	1.3	± 0.3nH	8	9	25	45	12000	0.13	300
WL100505G1N5SGT03	1.5	± 0.3nH	8	9	23	43	10000	0.13	300
WL100505G1N8SGT03	1.8	± 0.3nH	8	9	24	43	9000	0.14	300
WL100505G2N0SGT03	2.0	± 0.3nH	8	9	26	45	9000	0.16	300
WL100505G2N2SGT03	2.2	± 0.3nH	8	9	26	45	9000	0.16	300
WL100505G2N4SGT03	2.4	± 0.3nH	8	9	26	42	9000	0.17	300
WL100505G2N7SGT03	2.7	± 0.3nH	8	9	26	42	8000	0.17	300
WL100505G3N0SGT03	3.0	± 0.3nH	8	9	26	42	8000	0.19	300
WL100505G3N3SGT03	3.3	± 0.3nH	8	9	26	42	6500	0.19	300
WL100505G3N6SGT03	3.6	± 0.3nH	8	9	26	40	6000	0.22	300
WL100505G3N9□GT03	3.9	± 0.3nH ±10% nH	8	9	26	40	6000	0.22	300
WL100505G4N3□GT03	4.3	± 0.3nH ±10% nH	8	9	26	42	6000	0.24	300
WL100505G4N7□GT03	4.7	± 0.3nH ±10% nH	8	9	27	46	5000	0.23	300
WL100505G5N1□GT03	5.1	± 0.3nH ±10% nH	8	9	27	44	5000	0.27	300
WL100505G5N6□GT03	5.6	± 0.3 nH ±10% nH	8	10	28	40	4700	0.27	300
WL100505G6N8□GT03	6.8	±5%nH ±10%nH	8	10	28	36	4500	0.32	250
WL100505G7N5□GT03	7.5	±5%nH ±10%nH	8	10	28	35	4500	0.35	250
WL100505G8N2□GT03	8.2	±5% nH ±10% nH	8	10	28	36	4000	0.37	250
WL100505G9N1□GT03	9.1	±5%nH ±10%nH	8	10	28	36	4000	0.40	250

*: 500MHz, **: 1000MH

【Test Instruments】

L.Q.: HP4291B (Text Fixture: HP16192A), RDC: HP4263B,
SRF: Anritsu 37247B, IDC: HP6612C

Walsin Part Number	L(nH)	Tolerance	Q Min (MHz)	Typical Q @ Frequency (MHz)			SRF Typical (MHz)	RDC Maximum (Ω)	IDC (mA)
			100	100	800	1800			
WL100505G10N□GT03	10	±5% nH ±10% nH	8	10	27	33	3500	0.42	250
WL100505G12N□GT03	12	±5% nH ±10% nH	8	11	31	41	3000	0.48	250
WL100505G15N□GT03	15	±5% nH ±10% nH	8	10	27	33	2900	0.53	250
WL100505G18N□GT02	18	±5% nH ±10% nH	8	11	29	31	2200	0.65	200
WL100505G20N□GT02	20	±5% nH ±10% nH	8	10	26	15	2100	0.80	200
WL100505G22N□GT02	22	±5% nH ±10% nH	8	10	26	15	2100	0.80	200
WL100505G27N□GT02	27	±5% nH ±10% nH	8	10	23	15	2000	0.90	200
WL100505G33N□GT02	33	±5% nH ±10% nH	8	10	*22	**24	1900	1.00	200
WL100505G39N□GT02	39	±5% nH ±10% nH	8	10	*19	**20	1800	1.20	200
WL100505G43N□GT02	43	±5% nH ±10% nH	8	10	*22	**20	1500	1.30	200
WL100505G47N□GT02	47	±5% nH ±10% nH	8	12	*22	**20	1500	1.30	200
WL100505G56N□GT02	56	±5% nH ±10% nH	8	12	*22	**18	1400	1.60	200
WL100505G68N□GT02	68	±5% nH ±10% nH	8	11	*18	**10	1200	1.90	180
WL100505G82N□GT02	82	±5% nH ±10% nH	8	12	*20	**7	1100	2.10	150
WL100505GR10□GT01	100	±5% nH ±10% nH	8	11	*18	-	930	2.30	100

*: 500MHz, **: 1000MHz
【Test Instruments】
L.Q.: HP4291B (Text Fixture: HP16192A), RDC: HP4263B,
SRF: Anritsu 37247B, IDC: HP6612C

ELECTRICAL CHARACTERISTICS

Quality Factor vs. Frequency

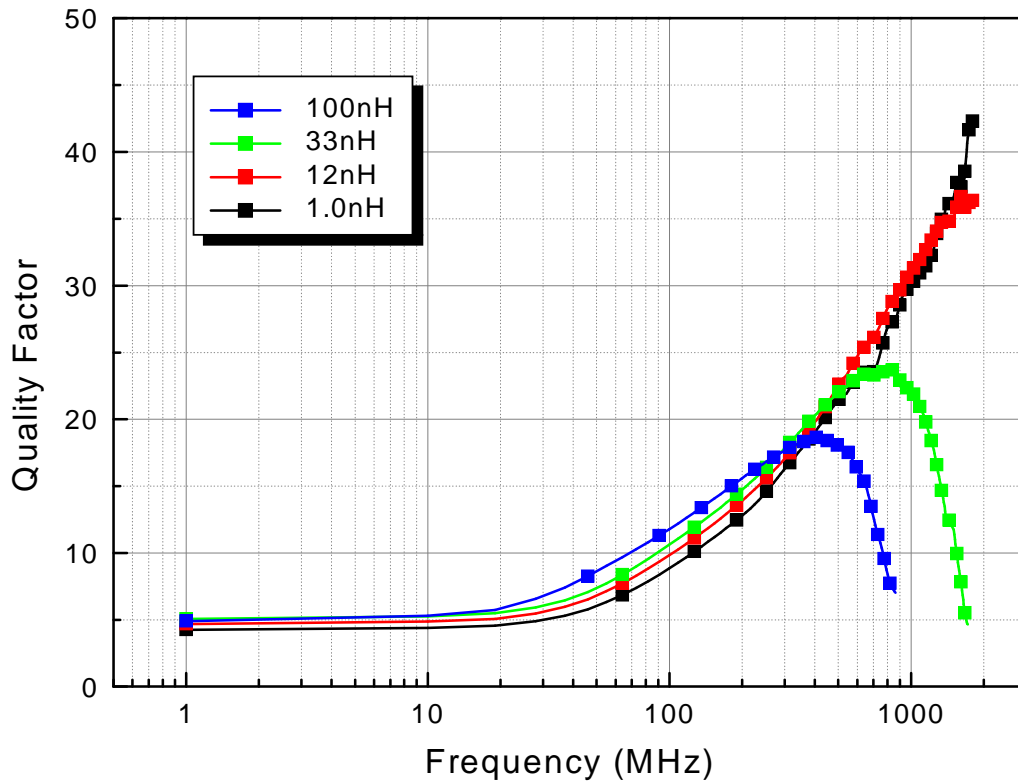

Inductance vs. Frequency

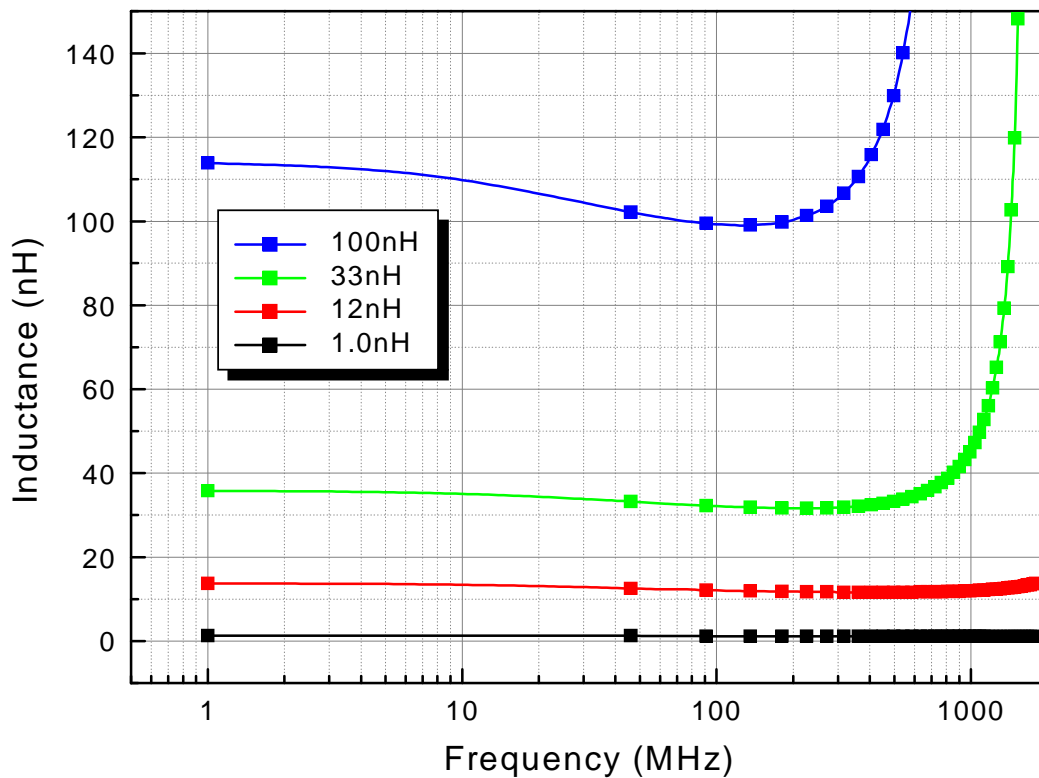

STANARD TEST and RELIABILITY TEST

- Temperature : 15~35°C
- Humidity : 25%RH~85%RH
- Atmospheric pressure : 96kPa ~ 106kPa

1. Electrical performance test

Item	Method & Criteria
Inductance/Q(Quality factor)	Unit : nH/Constant
	Test frequency : 100MHz
	Equipment : Impedance material analyzer
SRF(Self Resonant Frequency)	Unit : MHz
	Test frequency : Frequency sweep(40MHz~20GHz)
	Equipment : Network analyzer
DC(Direct Current)resistance	Unit : mΩ(ohm)
	Test frequency : LCR meter
Rated current	Unit : mA
	Test frequency : Current Sweep
	Equipment : Power supply (DC current source)

2. Reliability Test

TCL	Unit : Temperature coefficient of L(PPM/°C) Test Temperature : -40°C~125°C (referring to L at 20°C) Equipment : TC Chamber(with Impedance analyzer, Ohmmeter, power supply PC, Printer) ◇ Basically, DC bias make no difference on L and Q, in glass ceramic inductors Requirements : L shall be within ±10% of the initial value.																				
Thermal Resistance (Temperature cycle)	Unit : Appearance, Electrical Characteristics Test condition : <table border="1" style="margin: 10px auto;"> <thead> <tr> <th>Step</th> <th>1</th> <th>2</th> <th>3</th> <th>4</th> </tr> </thead> <tbody> <tr> <td>Temp.</td> <td>-40±2°C</td> <td>room temp.</td> <td>+125±2°C</td> <td>room temp.</td> </tr> <tr> <td>Time</td> <td>30min</td> <td>2-3min</td> <td>30min</td> <td>2-3min</td> </tr> <tr> <td>Cycle</td> <td colspan="4" style="text-align: center;">100 cycles/test</td> </tr> </tbody> </table> Equipment : TC chamber or Temp. controlled chamber (programmable) Procedure : 1) Measure the initial values(L,Q,Rdc) 2) Carry out the test as described above 3) make measurements after ambient air exposure for 24±2 hours. Requirements : No apparent damage L shall be within ±10% of the initial value. Q shall be within ±20% of the initial value.	Step	1	2	3	4	Temp.	-40±2°C	room temp.	+125±2°C	room temp.	Time	30min	2-3min	30min	2-3min	Cycle	100 cycles/test			
Step	1	2	3	4																	
Temp.	-40±2°C	room temp.	+125±2°C	room temp.																	
Time	30min	2-3min	30min	2-3min																	
Cycle	100 cycles/test																				

Humidity Resistance	<p>Unit : Mechanical, Electrical Characteristics</p> <p>Test condition : Humidity :90-95%RH Temp :60°C Time : 500±12 hours neglected.</p> <p>Equipment : Constant temperature & humidity chamber</p> <p>Procedure : 1) Measure the initial values(L,Q,Rdc) 2) Carry out the test as described above 3) make measurements after ambient air exposure for 24±2 hours.</p> <p>Requirements : No apparent damage L shall be within ±10% of the initial value. Q shall be within ±20% of the initial value.</p>
High Temperature Resistance	<p>Unit : Mechanical, Electrical Characteristics</p> <p>Test condition : Temp.; 125±2°C Time ;1000±12 hours under unloading.</p> <p>Equipment : Constant temperature & humidity chamber</p> <p>Procedure : 1) Measure the initial values(L, Q, Rdc) 2) Carry out the test as described above 3) make measurements after ambient air exposure for 24±2 hours.</p> <p>Requirements : No apparent damage L shall be within ±10% of the initial value. Q shall be within ±20% of the initial value.</p>
Low Temperature Resistance	<p>Unit : Mechanical, Electrical Characteristics</p> <p>Test condition : Temp.; -40±2°C Time ;1000±12 hours under unloading.</p> <p>Equipment : Constant temperature & humidity chamber</p> <p>Procedure : 1) Measure the initial values(L, Q, Rdc) 2) Carry out the test as described above 3) make measurements after ambient air exposure for 24±2 hours.</p> <p>Requirements : No apparent damage L shall be within ±10% of the initial value. Q shall be within ±20% of the initial value.</p>

8585 Test	<p>Unit : Mechanical, Electrical Characteristics</p> <p>Test condition : Temp. : 85±2°C Humidity : 85±5% Time : 100±12 hours</p> <p>Equipment : Constant temperature & humidity chamber</p> <p>Procedure : 1) Measure the initial values(L, Q, Rdc) 2) Carry out the test as described above 3) Make measurements after the ambient air exposure for 24±2 hours</p> <p>Requirements : No mechanical damage L shall be within ±10% of the initial value. Q shall be within ±20% of the initial value.</p>
Loading under Damp Heat	<p>Unit : Mechanical, Electrical Characteristics</p> <p>Test condition : Temp : 60±2°C Humidity : 90~95%RH Time : 500±12 hours Apply current: Rated current</p> <p>Equipment : Constant temperature & humidity chamber</p> <p>Procedure : 1) Measure the initial values(L, Q, Rdc) 2) Carry out the test as described above 3) Make measurements after the ambient air exposure for 1 to 2 hours of recovery</p> <p>Requirements : No mechanical damage L shall be within ±10% of the initial value. Q shall be within ±20% of the initial value.</p>
Loading at High Temperature	<p>Unit : Mechanical, Electrical Characteristics</p> <p>Test condition : Temp : 125±2°C Time : 500±12 hours Apply current: Rated current</p> <p>Equipment : Constant temperature & humidity chamber</p> <p>Procedure : 1) Measure the initial values(L, Q, Rdc) 2) Carry out the test as described above 3) Make measurements after the ambient air exposure for 1 to 2 hours of recovery</p> <p>Requirements : No mechanical damage L shall be within ±10% of the initial value. Q shall be within ±20% of the initial value.</p>

3. Solderability

Condition	Immerse a test sample into a methanol solution containing rosin and immerse into molten solder of $245\pm 5^{\circ}\text{C}$ for 5~10 seconds.
Requirement	More than 75% of the terminal electrode part shall be covered with fresh solder.

4. Resistance to soldering heat

Condition	-Immerse a test sample into a methanol solution containing resin, preheat it at 120 to 150°C for 1 minutes and immerse into molten solder of $270\pm 5^{\circ}\text{C}$ for 10 ± 1 second so that both terminal electrodes are completely submerged.
Requirement	No visible damage Inductance variation within 10% Q variation within 20%

5. Bending Strength

Condition	Solder the chip to test jig then apply a force in the direction shown in below. The soldering shall be done with the reflow method and shall be conducted with care so that the soldering is uniform and free of defects such as heat shock.
Requirement	1. No mechanical damage shall be observed. 2. Rdc-value: to meet the initial Spec.

6. IR Reflow Profile

The rate of preheat should not exceed $4^{\circ}\text{C}/\text{sec}$ and a target of $2^{\circ}\text{C}/\text{sec}$ is preferred. Ceramic chip components should be preheated to within 100 to 130°C of the soldering

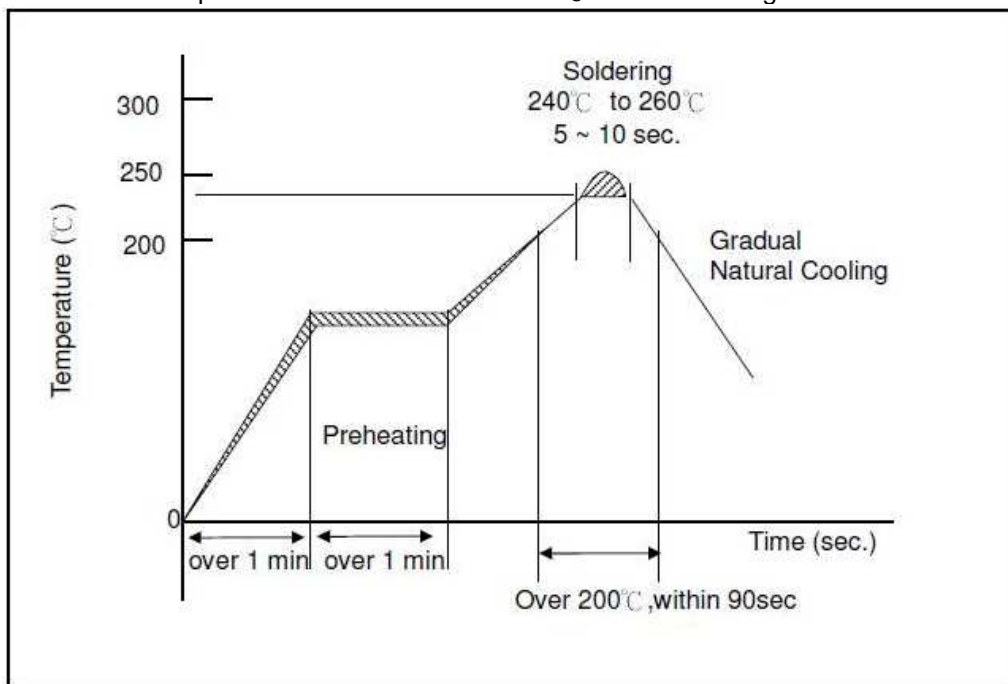

SOLDERING CONDITION

Typical examples of soldering processes that provide reliable joints without any damage are given in figure below:

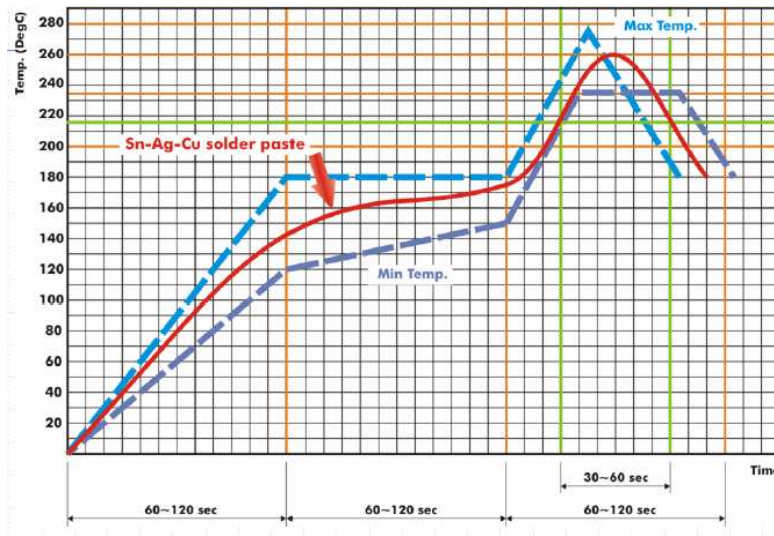

Infrared soldering profile

PACKAGE SPECIFICATION

Carrier Tape Dimensions

- Carrier Tape material : Paper
- Dimension in millimeters

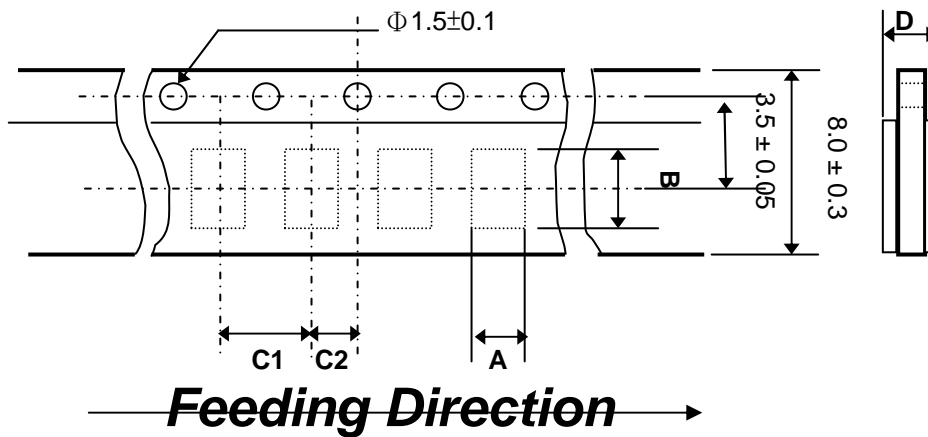

Series	Chip cavity	Chip cavity	Insertion pitch	Insertion pitch	Tape thickness
	A	B	C1	C2	D
1005	0.685 ± 0.015	1.215 ± 0.015	2.0 ± 0.1	2.0 ± 0.05	0.8max

Dimensions of Taping

-Leader and blank section

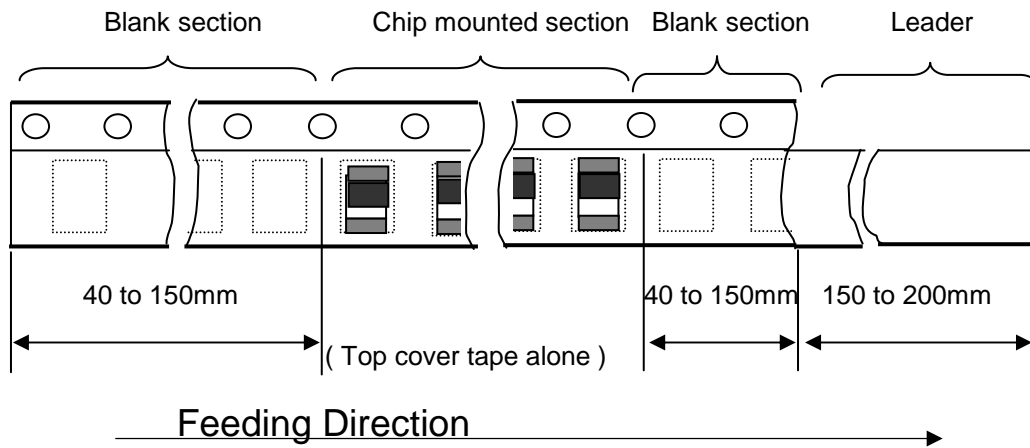

Appearance of taping

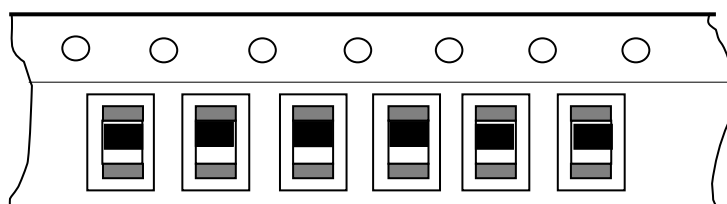
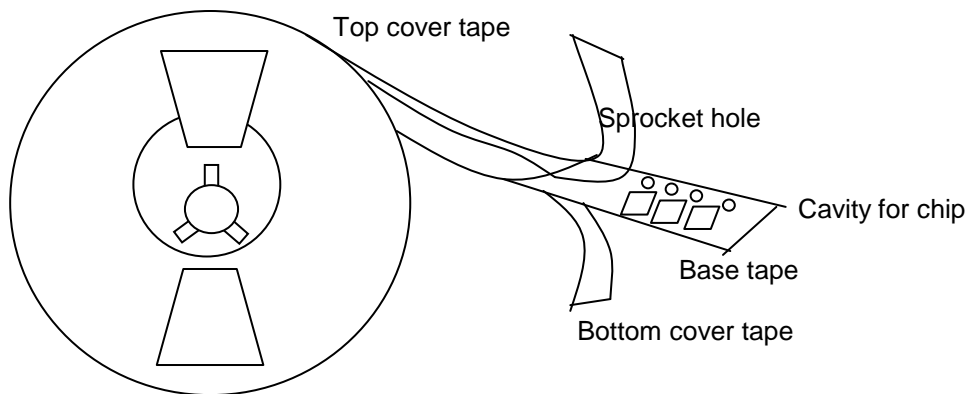

Packed chip

Reel Dimensions

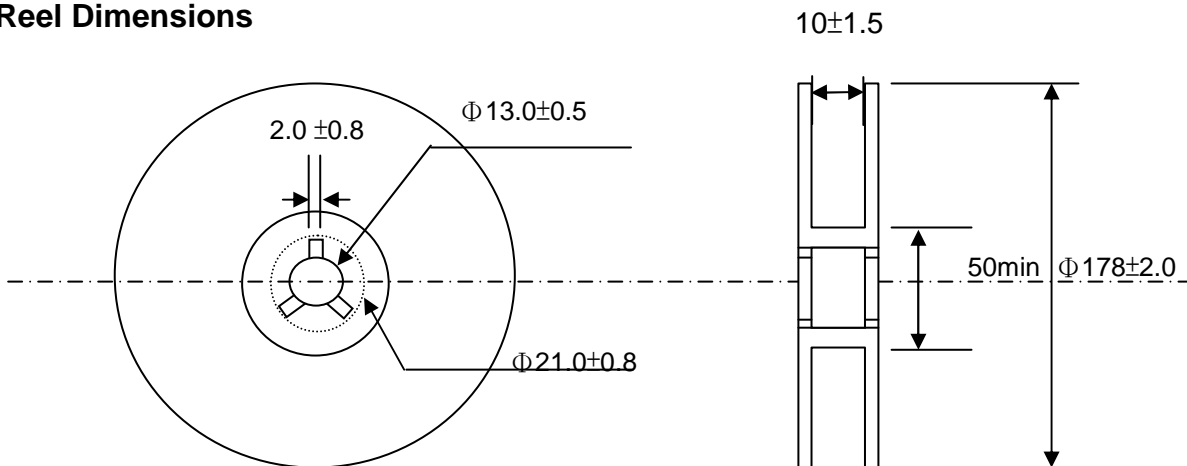

- Reel material : Polystyrene
- Ordering code No., Quantity, Batch No. and Walsin
- Parts per reel : 10,000 pcs / reel

CAUTION OF HANDLING

Limitation of Applications

Please contact us before using our products for the applications listed below which require especially high reliability for the prevention of defects, which might directly cause damage to the third party's life, body or property.

- (1) Aircraft equipment
- (2) Aerospace equipment
- (3) Undersea equipment
- (4) Medical equipment
- (5) Disaster prevention / crime prevention equipment
- (6) Traffic signal equipment
- (7) Transportation equipment (vehicles, trains, ships, etc.)
- (8) Applications of similar complexity and /or reliability requirements to the applications listed in the above.

Storage condition

- (1) Products should be used in 6 months from the day of WALSIN outgoing inspection, which can be confirmed.
- (2) Storage environment condition.
 - Products should be storage in the warehouse on the following conditions.
 - Temperature : -10 to +40°C
 - Humidity : 30 to 70% relative humidity
 - Don't keep products in corrosive gases such as sulfur. Chlorine gas or acid or it may cause oxidization of electrode, resulting in poor solderability.
 - Products should be storage on the palette for the prevention of the influence from humidity, dust and son on.
 - Products should be storage in the warehouse without heat shock, vibration, direct sunlight and so on.
 - Products should be storage under the airtight packaged condition.

APPROVAL SHEET

MULTI LAYER CERAMIC INDUCTOR

High Frequency Application Purpose

Size 0603 (1608)

WL1608 Pb-Free Series

*Contents in this sheet are subject to change without prior notice.

FEATURES

1. Ceramic structure provides high reliability · high productivity
2. Product Design via 3D EM Simulation Skill makes excellent Q and SRF characteristics
3. Miniaturized size 1.6 x 0.8 x 0.8 mm³
4. Pb Free products

APPLICATIONS

Portable electronics and wireless segment include mobile phones, WLAN, HomeRF, Bluetooth application, telecommunication and EMI countermeasure in high frequency circuits.

DESCRIPTION

Walsin Technology Corporation develops a tiny size of 1.6 x 0.8 x 0.8 mm³ Multi Layer Ceramic Inductor (MLCI) consists of a rectangular block of ceramic foils on which low resistive silver metal electrodes are contained and connected via through hole. The inner electrodes are then connected to the two terminations. Adopt 3D EM simulation skill for product design makes Walsin Technology Corporation MLCIs provide excellent Q_Value and Self Resonant Frequency (SRF) characteristics to address application on high frequency band as well as on EMI suppression. The Walsin High frequency chip inductors are manufactured by Multilayer fabrication technology providing excellent electrical performance. The inductors are supplied in reel taping, making them suitable for automatic Pick & Place equipment.

Cooperating with environmental protection, We provided Pb-Free products for customer request.

SHAPE AND DIMENSIONS

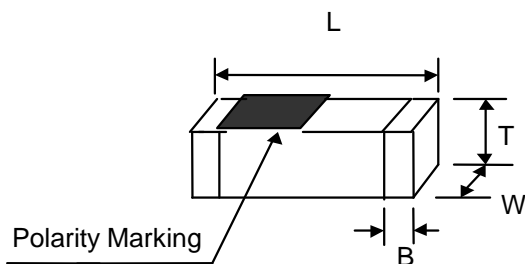

MARKING

Polarity mark



Unit: mm (inches)

	L	W	T	B
1608	1.6 [0.063] ±0.15 [0.005]	0.8 [0.031] ±0.15 [0.005]	0.8 [0.032] ±0.15 [0.005]	0.3 [0.012] ±0.20 [0.005]

Ordering Information

WL	16 08 08	G	4N7	S	G	T	03
Product Code	Dimension code	Material	Inductance	Tolerance	Specification	Packing Code	Rated Current
WL: Inductor	160808 = L: 1.6mm W: 0.8mm T: 0.8mm	A, B, C, D, E, F, G	For Ls < 10nH, N = Decimal Point e.g. 4N7 = 4.7nH	S: ± 0.3nH J: ± 5%	N= Normal A= ± 0.2nH G= Green	T= Reeled B = Bulk	03= 250mA or 300mA 02= 150mA or 200mA

ELECTRICAL SPECIFICATION – 0603 (1608) MLCI

■ Operating Temperature range : -40°C ~ 85°C

Walsin Part Number	L(nH)	Tolerance	Q Min (MHz)	Typical Q @ Frequency (MHz)			SRF Typical (MHz)	RDC Maximum (Ω)	IDC (mA)
				100	100	800			
WL160808G1N0SGT03	1.0	± 0.3nH	8	13	44	60	8100	0.10	300
WL160808G1N2SGT03	1.2	± 0.3nH	8	13	44	60	8100	0.10	300
WL160808G1N5SGT03	1.5	± 0.3nH	8	14	37	56	8100	0.10	300
WL160808G1N8SGT03	1.8	± 0.3nH	8	12	37	55	8300	0.10	300
WL160808G2N2SGT03	2.2	± 0.3nH	8	12	38	54	8000	0.10	300
WL160808G2N7SGT03	2.7	± 0.3nH	8	13	38	53	7600	0.10	300
WL160808G3N3SGT03	3.3	± 0.3nH	8	12	37	49	5800	0.12	300
WL160808G3N9SGT03	3.9	± 0.3nH	8	14	44	62	5100	0.14	300
WL160808G4N7SGT03	4.7	± 0.3nH	8	15	43	63	4600	0.16	300
WL160808G5N6SGT03	5.6	± 0.3nH	8	15	45	59	4200	0.18	300
WL160808G6N8JGT03	6.8	± 5%	8	15	43	58	3700	0.22	300
WL160808G8N2JGT03	8.2	± 5%	8	15	44	52	3600	0.24	300
WL160808G10NJGT03	10	± 5%	12	17	49	50	3500	0.26	300
WL160808G12NJGT03	12	± 5%	12	15	41	37	2500	0.28	300
WL160808G15NJGT03	15	± 5%	12	17	45	35	2600	0.32	300
WL160808G18NJGT03	18	± 5%	12	16	45	39	2000	0.35	300
WL160808G22NJGT03	22	± 5%	12	16	43	21	1800	0.40	300
WL160808G27NJGT03	27	± 5%	12	16	41	11	1600	0.45	300
WL160808G33NJGT03	33	± 5%	12	19	41	11	1500	0.55	300
WL160808G39NJGT03	39	± 5%	12	19	42	17	1400	0.60	300
WL160808G47NJGT03	47	± 5%	12	17	35	-	1300	0.70	300
WL160808G56NJGT03	56	± 5%	12	19	31	-	1300	0.75	300
WL160808G68NJGT03	68	± 5%	12	19	26	-	1150	0.85	300
WL160808G82NJGT03	82	± 5%	12	19	21	-	1000	0.95	300
WL160808GR10JGT03	100	± 5%	12	19	20	-	1000	1.00	300
WL160808GR12JGT03	120	± 5%	12	19	16	-	950	1.20	300
WL160808GR15JGT03	150	± 5%	12	19	-	-	800	1.50	300
WL160808GR18JGT03	180	± 5%	12	19	-	-	750	1.90	300
WL160808GR22JGT03	220	± 5%	12	18	-	-	680	2.20	300
WL160808GR27JGT03	270	± 5%	12	20	-	-	600	2.50	300

【Test Instruments】
L.Q.: HP4291B (Text Fixture: HP16192A), RDC: HP4263B,
SRF: Anritsu 37247B, IDC: HP6612C

ELECTRICAL CHARACTERISTICS

Quality Factor vs. Frequency

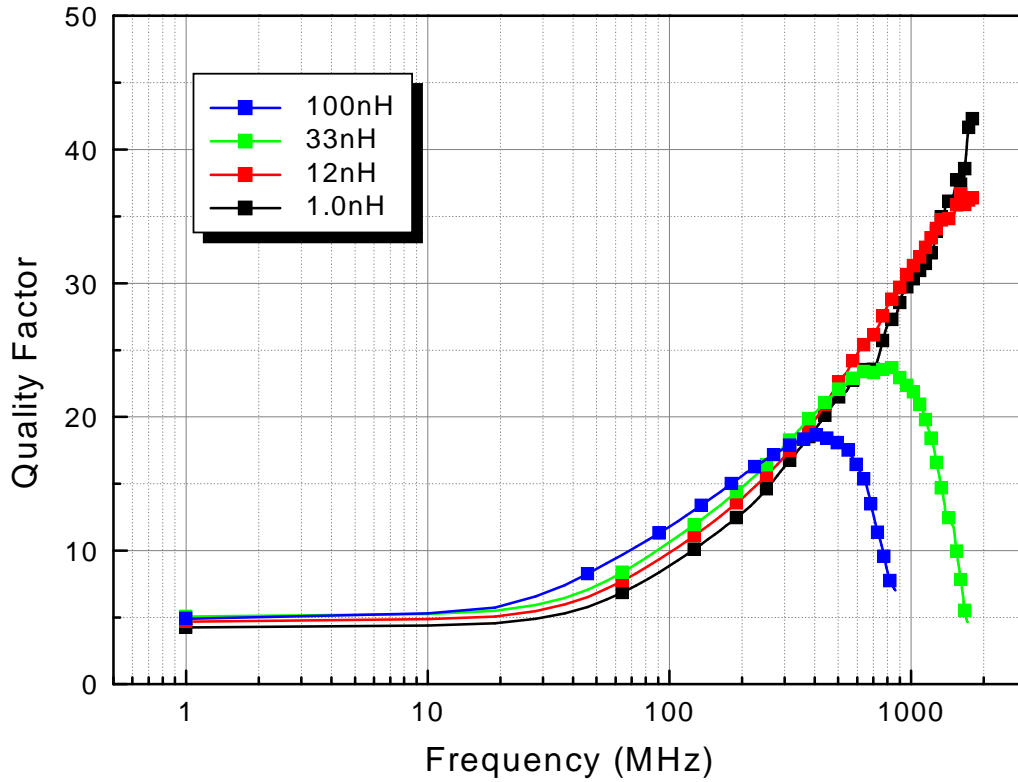

Inductance vs. Frequency

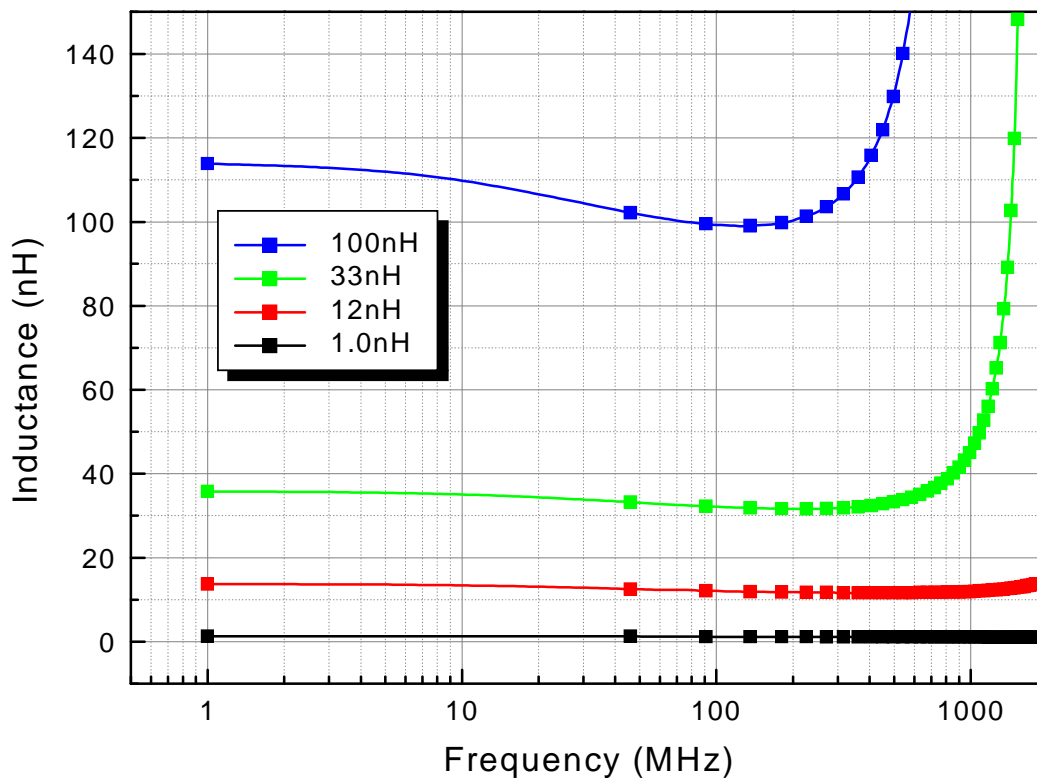

STANARD TEST and RELIABILITY TEST

- Temperature : 15~35°C
- Humidity : 25%RH~85%RH
- Atmospheric pressure : 96kPa ~ 106kPa

1. Electrical performance test

Item	Method & Criteria
Inductance/Q(Quality factor)	Unit : nH/Constant Test frequency : 100MHz Equipment : Impedance material analyzer
SRF(Self Resonant Frequency)	Unit : MHz Test frequency : Frequency sweep(40MHz~20GHz) Equipment : Network analyzer
DC(Direct Current)resistance	Unit : mΩ (ohm) Test frequency : LCR meter
Rated current	Unit : mA Test frequency : Current Sweep Equipment : Power supply (DC current source)

2. Reliability Test

TC	Unit : Temperature coefficient of L(PPM/°C) Test Temperature : -40°C~125°C(referring to L at 20°C) Equipment : TC Chamber(with Impedance analyzer, Ohmmeter, power supply PC, Printer) ◇ Basically, DC bias make no difference on L and Q, in glass ceramic inductors Requirements : L shall be within ±10% of the initial value.																				
Thermal Resistance (Temperature cycle)	Unit : Mechanical, Electrical Characteristics Test condition : <table border="1" style="margin: 10px auto;"> <thead> <tr> <th>Step</th> <th>1</th> <th>2</th> <th>3</th> <th>4</th> </tr> </thead> <tbody> <tr> <td>Temp.</td> <td>-40±2°C</td> <td>room temp.</td> <td>+125±2°C</td> <td>room temp.</td> </tr> <tr> <td>Time</td> <td>30min</td> <td>2-3min</td> <td>30min</td> <td>2-3min</td> </tr> <tr> <td>Cycle</td> <td colspan="4" style="text-align: center;">100 cycles/test</td> </tr> </tbody> </table> Equipment : TC chamber or Temp. controlled chamber (programmable) Procedure : 1) Measure the initial values(L,Q,Rdc) 2) Carry out the test as described above 3) make measurements after ambient air exposure for 24±2 hours. Requirements : No apparent damage L shall be within ±10% of the initial value. Q shall be within ±20% of the initial value.	Step	1	2	3	4	Temp.	-40±2°C	room temp.	+125±2°C	room temp.	Time	30min	2-3min	30min	2-3min	Cycle	100 cycles/test			
Step	1	2	3	4																	
Temp.	-40±2°C	room temp.	+125±2°C	room temp.																	
Time	30min	2-3min	30min	2-3min																	
Cycle	100 cycles/test																				

Humidity Resistance	<p>Unit : Mechanical, Electrical Characteristics</p> <p>Test condition : Humidity :90-95%RH Temp :60°C Time : 500±12 hours neglected.</p> <p>Equipment : Constant temperature & humidity chamber</p> <p>Procedure : 1) Measure the initial values(L,Q,Rdc) 2) Carry out the test as described above 3) make measurements after ambient air exposure for 24±2 hours.</p> <p>Requirements : No apparent damage L shall be within ±10% of the initial value. Q shall be within ±20% of the initial value.</p>
High Temperature Resistance	<p>Unit : Mechanical, Electrical Characteristics</p> <p>Test condition : Temp.; 125±2°C Time ;1000±12 hours under unloading.</p> <p>Equipment : Constant temperature & humidity chamber</p> <p>Procedure : 1) Measure the initial values(L, Q, Rdc) 2) Carry out the test as described above 3) make measurements after ambient air exposure for 24±2 hours.</p> <p>Requirements : No apparent damage L shall be within ±10% of the initial value. Q shall be within ±20% of the initial value.</p>
Low Temperature Resistance	<p>Unit : Mechanical, Electrical Characteristics</p> <p>Test condition : Temp.; -40±2°C Time ;1000±12 hours under unloading.</p> <p>Equipment : Constant temperature & humidity chamber</p> <p>Procedure : 1) Measure the initial values(L, Q, Rdc) 2) Carry out the test as described above 3) make measurements after ambient air exposure for 24±2 hours.</p> <p>Requirements : No apparent damage L shall be within ±10% of the initial value. Q shall be within ±20% of the initial value.</p>

8585 Test	<p>Unit : Mechanical, Electrical Characteristics</p> <p>Test condition : Temp. : 85±2°C Humidity : 85±5% Time : 100±12 hours</p> <p>Equipment : Constant temperature & humidity chamber</p> <p>Procedure : 1) Measure the initial values(L, Q, Rdc) 2) Carry out the test as described above 3) Make measurements after the ambient air exposure for 24±2 hours</p> <p>Requirements : No mechanical damage L shall be within ±10% of the initial value. Q shall be within ±20% of the initial value.</p>
Loading under Damp Heat	<p>Unit : Mechanical, Electrical Characteristics</p> <p>Test condition : Temp : 60±2°C Humidity : 90~95%RH Time : 500±12 hours Apply current: Rated current</p> <p>Equipment : Constant temperature & humidity chamber</p> <p>Procedure : 1) Measure the initial values(L, Q, Rdc) 2) Carry out the test as described above 3) Make measurements after the ambient air exposure for 1 to 2 hours of recovery</p> <p>Requirements : No mechanical damage L shall be within ±10% of the initial value. Q shall be within ±20% of the initial value.</p>
Loading at High Temperature	<p>Unit : Mechanical, Electrical Characteristics</p> <p>Test condition : Temp : 125±2°C Time : 500±12 hours Apply current: Rated current</p> <p>Equipment : Constant temperature & humidity chamber</p> <p>Procedure : 1) Measure the initial values(L, Q, Rdc) 2) Carry out the test as described above 3) Make measurements after the ambient air exposure for 1 to 2 hours of recovery</p> <p>Requirements : No mechanical damage L shall be within ±10% of the initial value. Q shall be within ±20% of the initial value.</p>

3. Solderability

Condition	Immerse a test sample into a methanol solution containing rosin and immerse into molten solder of $245\pm 5^{\circ}\text{C}$ for 5~10 seconds
Requirement	More than 75% of the terminal electrode part shall be covered with fresh solder.

4. Resistance to soldering heat

Condition	Immerse a test sample into a methanol solution containing resin, preheat it at 120 to 150°C for 1 minutes and immerse into molten solder of $270\pm 5^{\circ}\text{C}$ for 10 ± 1 second so that both terminal electrodes are completely submerged.
Requirement	No visible damage Inductance variation within 10%Q variation within 20%

5. Bending Strength

Condition	Solder the chip to test jig then apply a force in the direction shown in below. The soldering shall be done with the reflow method and shall be conducted with care so that the soldering is uniform and free of defects such as heat shock.
Requirement	1. No mechanical damage shall be observed. 2. Rdc-value: to meet the initial Spec.

6. IR Reflow Profile

The rate of preheat should not exceed $4^{\circ}\text{C}/\text{sec}$ and a target of $2^{\circ}\text{C}/\text{sec}$ is preferred. Ceramic chip components should be preheated to within 100 to 130°C of the soldering

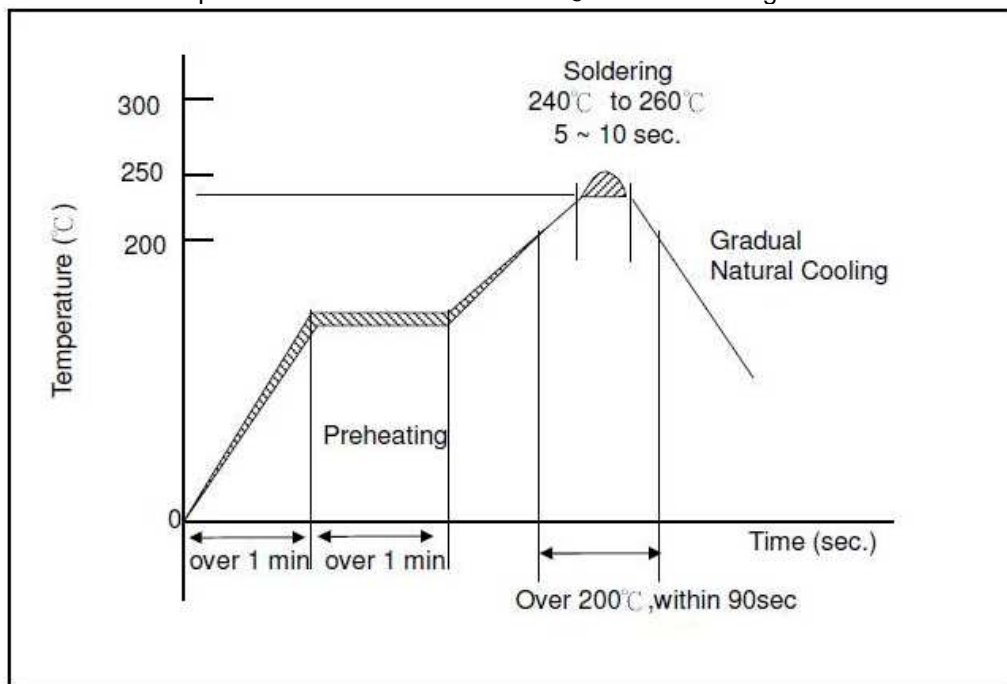

PACKAGE SPECIFICATION

Carrier Tape Dimensions

- Carrier Tape material : Paper
- Dimension in millimeters

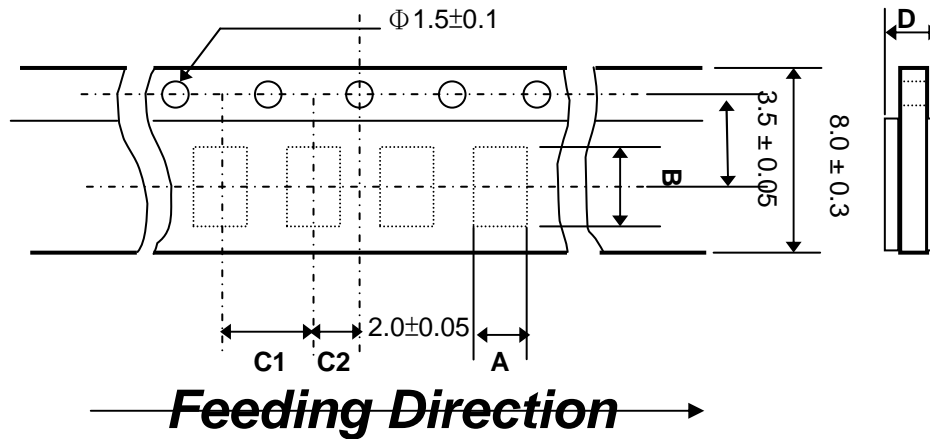

Series	Chip cavity	Chip cavity	Insertion pitch	Insertion pitch	Tape thickness
	A	B	C1	C2	D
1608	1.0 ± 0.1	1.8 ± 0.1	4.0 ± 0.1	2.0 ± 0.05	1.2max

Dimensions of Taping

-Leader and blank section

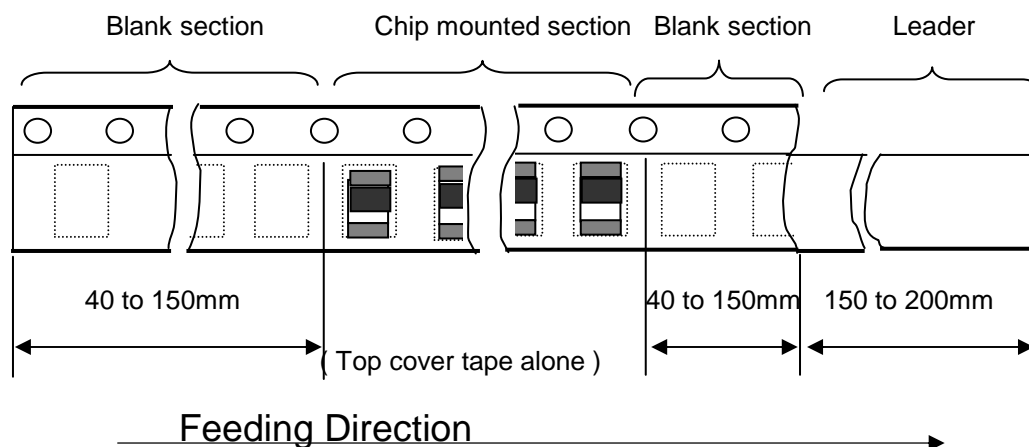

Appearance of taping

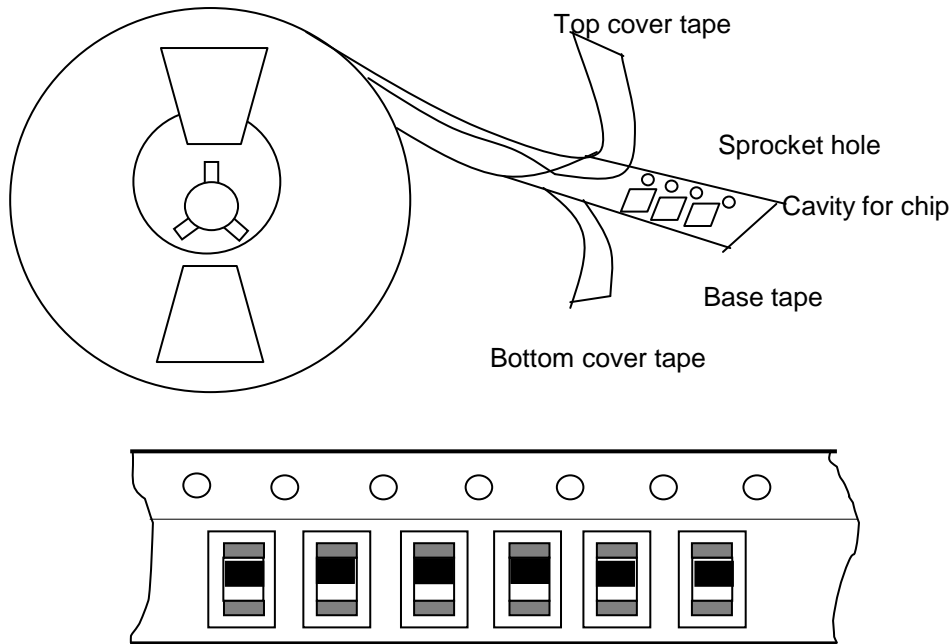

Packed chip

Reel Dimensions

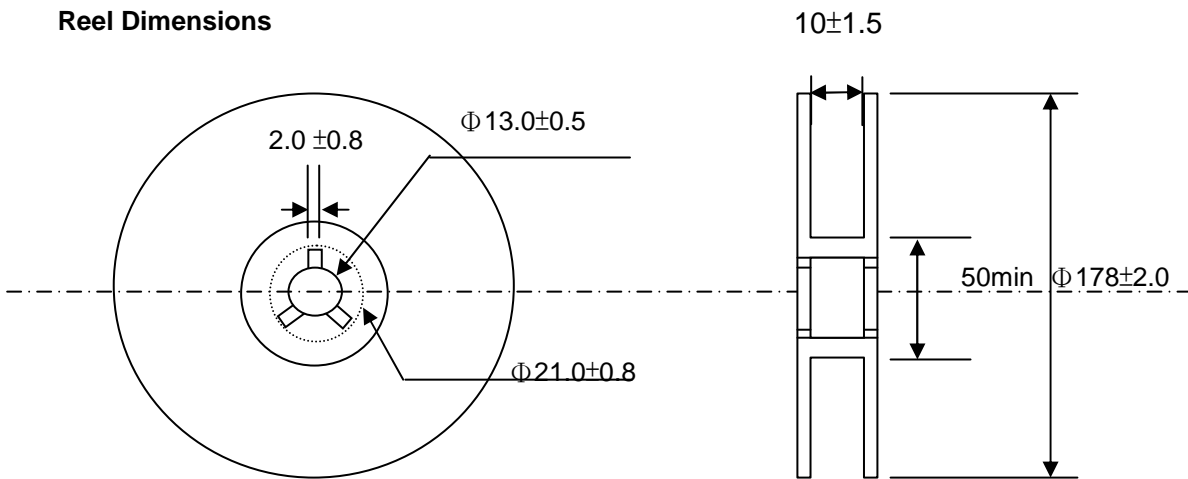

1. Reel material : Polystyrene
2. Ordering code No., Quantity, Batch No. and Walsin
3. Parts per reel : 4,000 pcs / reel

CAUTION OF HANDLING

Limitation of Applications

Please contact us before using our products for the applications listed below which require especially high reliability for the prevention of defects, which might directly cause damage to the third party's life, body or property.

- (1) Aircraft equipment
- (2) Aerospace equipment
- (3) Undersea equipment
- (4) Medical equipment
- (5) Disaster prevention / crime prevention equipment
- (6) Traffic signal equipment
- (7) Transportation equipment (vehicles, trains, ships, etc.)
- (8) Applications of similar complexity and /or reliability requirements to the applications listed in the above.

Storage condition

- (1) Products should be used in 6 months from the day of WAL SIN outgoing inspection, which can be confirmed.
- (2) Storage environment condition.
 - Products should be storage in the warehouse on the following conditions.
 - Temperature : -10 to +40°C
 - Humidity : 30 to 70% relative humidity
 - Don't keep products in corrosive gases such as sulfur. Chlorine gas or acid or it may cause oxidization of electrode, resulting in poor solderability.
 - Products should be storage on the palette for the prevention of the influence from humidity, dust and son on.
 - Products should be storage in the warehouse without heat shock, vibration, direct sunlight and so on.
 - Products should be storage under the airtight packaged condition.